

ELECTRONIC TEST:

- 1.OPEN/SHORT/INTERMITTENCE: 100%.
- 2.HI-POT: AC 150V 0.01S
- 3.INSULATION RESISTANCE:DC300V 0.01S 10MΩ(MIN)
- 4.CONDUCTIVE RESISTANCE:3 OHM (MAX)
- 5.Transmission rate:18G
- 6.HD-TV:4K*2K @60Hz

Pin OUT

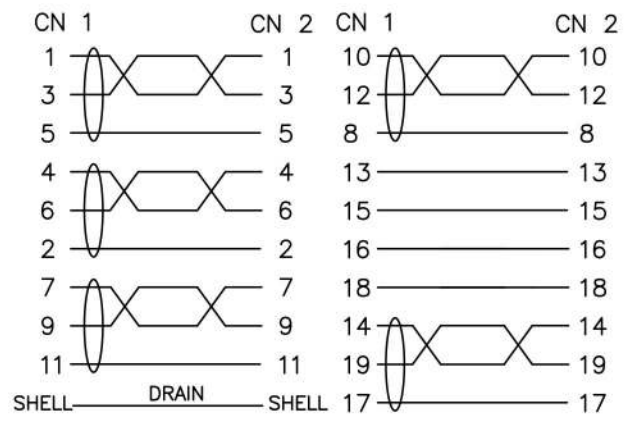

⑤	MOLDED	45P BLACK PVC		G
④	MOLDED	LD-PE		G
③	CONNECTOR	HDMI A Female Gold plated	1	PCS
②	CONNECTOR	HDMI A Male Gold plated	1	PCS
①	CABLE	(1/0.32BC*1P+1/0.32BC+AL)*5+1/0.32BC*4C+A+D(1/0.32BC)+B(80/0.12AL-MG) BLACK PVC OD:7.3±0.2MM PRINTING:High Speed HDMI Cable with Ethernet	2000	MM
NO.	MATERIAL	DESCRIPTION	QTY.	UNIT

Ltemref	Quantity	Title/Name,designation,material,dimension etc			Article No./Reference	
Designed by	Checked by	Approved by - date	File name	Date	Scale	
		18-01-2019		18-01-2019	FREE	
HDMI2.0 AM/F 3.0M						
UNIT:MM				26-70304K/MF	Edition	Sheet
				1	1/1	